

# Norriseal Series 1001, 1001A and 1001XL Level Controllers

Norriseal has been a leader in providing quality level measurement devices to the petroleum market for over five decades. In addition to oil and gas applications, Norriseal level products serve in marine, steel, and industrial markets.

This brochure describes the Series 1001, the 1001A, and the 1001XL liquid level controllers. The Series 1001 and 1001A can be right-hand or left-hand mounted while the 1001XL is used where back-mounting is preferred.



## Series 1001

The economical Series 1001 level controller uses a non-weatherproof case/cover.

## Series 1001A

The Series 1001A level controller uses a weather resistant sealed case and a manifold-style pilot assembly.

## Series 1001XL

The Series 1001XL level controller offers the features of a Series 1001A, but with a back-mount connection.

## Features

- **No-bleed pilots.** The pneumatic controller is equipped with one of three types of no-bleed pilots: a snap pilot, throttling pilot, or patented Envirosave™ pilot.
- **Removable door.** The controller door can only be removed after opening 90°. This feature prevents the door from vibrating loose while in the closed position. A lever latch keeps a positive engagement between the case and the door.
- **Weather-resistant sealed case (1001A & 1001XL).** An O-ring gasket seals internals from outside weather and allows the harmful exhaust gases to be vented to a remote area by tubing the vent connection to an exhaust manifold (when equipped with piped exhaust option).
- **Built-In filter.** A built-in 40-micron stainless steel filter in the gas supply connection reduces required maintenance of the controller's pilot.
- **Specific Gravities:** The controller can operate on multiple SG on interface or Top Level applications. Min SG available = 0.15 Max SG available = 1.20 Consult factory to select the proper spring range, arm length and displacer
- **Marine service.** Stainless steel internals are available.
- **Field-reversible action.** This adjustment determines whether rising liquid level will increase or decrease pilot output.
- **Right- or left-hand mount (1001 & 1001A).** The controller may be changed for right-hand or left-hand mount in the field without additional parts.
- **Electric controller.** This option utilizes a standard electric switch; SPDT or DPDT.
- **Split displacer.** For liquid dump spans greater than the standard displacers can provide, a split displacer can give dump spans up to 70 feet in length.
- **NACE.** All controllers can be configured to meet NACE MR0175-2002 specifications.

# Design

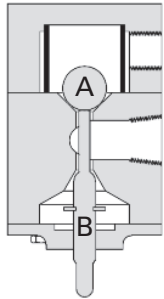

## Design snap pilot

The pilot is comprised of two valves – one to admit pilot pressure, and one to exhaust pressure.

Ball “A” controls the flow of gas into the pilot and is held closed with force exerted by supply pressure on the seating area of the ball.

## Snap pilot

When the force transmitted to thrust pin “B” is sufficient to overcome the force holding Ball “A” seated, “A” snaps upward allowing gas to flow past “A” and out the side port of the pilot.

The spherical end of thrust pin “B” closes the exhaust port the instant ball “A” snaps upward. The exhaust port seating area is smaller than the seating area of the supply port; therefore, the thrust pin will remain seated against supply pressure until force on the thrust pin diminishes.

A simultaneous action occurs as force is removed from thrust pin “B”. Pilot pressure opens the exhaust port by unseating the thrust pin, and supply pressure forces ball “A” to close the supply port. The difference in seating area gives this pilot Snap-Action. The pilot then vents through the thrust pin entry hole.

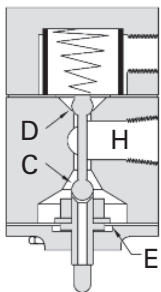

## Throttling pilot

Two valves are used to admit and exhaust pressure. A diaphragm “E” used in cooperation with the valves creates a Force-Balance Pilot.

The pilot output pressure acts upon the diaphragm so that the diaphragm pushes back with the same force being applied by the push rod. These balanced forces are the reason for the term “Force-Balance.”

## Throttling pilot

The throttle pilot works in the same manner as the snap pilot except the output pressure is proportioned to the amount of force applied to the pin. More force on the pin produces a proportionate increase in pilot pressure.

When the pin force changes, the pilot seeks a new balance point by either exhausting the output loading at valve “C” or unseating valve “D” to increase output loading. Instrument gas does not flow while the pilot is in balance.

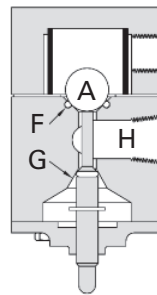

## Envirosave™ pilot

### Envirosave™ pilot

This patented pilot works identically to the snap pilot. The difference between the two is the O-ring seals “F” and “G,” which give a positive seal to eliminate leakage and prevent fugitive emissions. The EPA has independently measured the Envirosave pilot to have a zero CFH leak rate.\*

## Electric level switch

The electric level switch uses the force balance principle to open and close an electrical switch in response to rising or falling levels. Two standard switches are available, single pole double throw (SPDT) or double pole double throw (DPDT), both with explosion-proof enclosure.

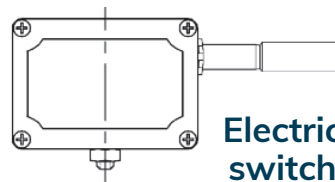

### Electric switch

\* United States of America. Air and Radiation. Environmental Protection Agency. Lessons Learned From Natural Gas Star Partners: Options for Reducing Methane Emissions From Pneumatic Devices in the Natural Gas Industry. Appendix A. Washington, DC, 2003.

# Principle of operation

## Force balance principle - theory of operation

The operation of the Series 1001, 1001A, and 1001XL level controllers is based on the Force Balance Principle. The **Force Balance Principle** states when an object is submerged in a liquid, it creates a buoyant force that is proportional to the weight of the liquid displaced. A Norriseal level controller uses a spring to balance the weight of a displacement-type element (displacer), eliminating the need for custom-weighted displacers and floats. As the displacer is immersed into the liquid, the amount of force available is proportional to the weight of the liquid displaced. The result of this force is transmitted to the controller by a rotational movement of the shaft. This rotational movement causes the fulcrum and lever (flapper bar) to push up the pilot thrust pin. The amount of force is proportional to the level on the displacer, creating a desired output signal. This desired output signal can be a pneumatic on/off signal using a snap pilot, a pneumatic modulating signal using a throttle pilot, or an electrical SPDT or DPDT signal by using an electric micro switch.

## Controller action

Controller action is "Direct Acting" when the output signal increases as the liquid level rises on the displacer. In "Reverse Acting," the output signal decreases as the liquid level increases on the displacer.

## Proportional band

Proportional band or span is the ratio of the displacer length used versus the total length of the displacer to achieve a desired output signal. For on/off control, the snap pilot output is equal to the supply pressure over the span of the controller. The span can be changed by sliding the fulcrum on the lever. Moving the fulcrum away from the pilot thrust pin increases the span, and moving the fulcrum towards the pilot decreases the span. For throttling control, the output will vary over the proportional band.

## Function of the adjustable spring

Not only does the spring balance the weight of the displacer, it can also be adjusted to shift the setpoint on the displacer. With spring force held constant, a higher liquid level on the displacer produces a larger force available to the pilot. When the spring force is reduced by decompressing the spring, a higher liquid level on the displacer is required to produce the same force as before. Increasing the spring force by compressing the spring requires a lower liquid level for the same force. Thus, increasing/decreasing the spring force will change the setpoint accordingly. The spring compression can be reduced further to a position where a hydrocarbon liquid level will not produce enough force to produce an output from the pilot. This makes the control of a **liquid interface** possible with the standard displacer. After the spring is adjusted so the lighter liquid will not operate the control, there is still adequate spring force in reserve for the liquid level of heavier liquid to provide enough force to actuate the pilot.

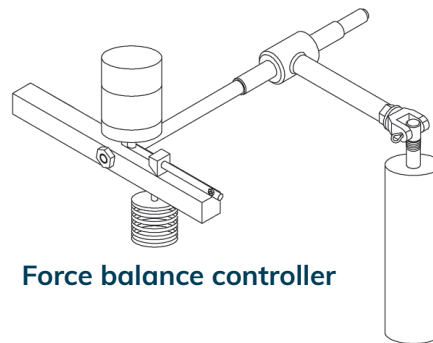

**Force balance controller**

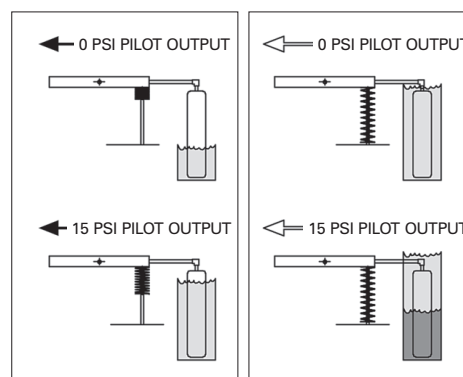

**Top-level control      Liquid interface control**

# Performance characteristics

PNEUMATIC PILOTS	
<b>Output – Zero to Supply</b>	
Proportional, throttle	3–15 psig, 6–30 psig
Differential gap, snap	0–20 psig, 0–30 psig
Differential gap, Envirosave™	0–20 psig, 0–30 psig
<b>Supply Pressure Requirement*</b>	
3–15 psig, 0–20 psig	20–30 psig (min.)
6–30 psig, 0–30 psig	35– 40 psig (min.)
0–50 psig	60 psig (max.)
0–100 psig*	100 psig (max.)
Supply and Output Connection	¼ inch NPT Female
Ambient Temperature	-40° to 180°F (-40° to 82°C) -40° to 275°F (High temp) (-40° to 135°C)
<b>Pilot Flow Capacity</b>	
Throttle Cv	0.394
Snap Cv	0.282
Envirosave™ Cv	0.282
<b>Proportional Band Adjustment</b> (Recommended adjustment for a full output pressure change over a percent of sensing element)	
Throttle	20–150%
Snap	7–55%
Envirosave™	7–55%

GENERAL	
<b>Output – Zero to Supply</b>	
Repeatability	1.0% of output span
Dead Band	5.0% of input span
Linearity	1.75% of output span
Ambient Temperature Effect on Setpoint	1.0% @ - 40°F (- 40°C) 3.0% @ +170°F (77°C)
Mechanical Disturbance Effects on Setpoint	1.0%
<b>Specific Gravity</b>	
Interface detection	0.035
Top level range	0.35 to 2.00
Temperature Limits Body process temperature (dependent on material selection)	-70° to +600°F (-57° to 316°C)
<b>Process Pressure Rating</b>	
Beveled - butt weld	To 6000 psig
Threaded (NPT)	To 6000 psig
Grooved	To 2500 psig
Flanged (RF & RTJ)	150 thru 2500 ANSI Class
Union w/sight glass	To 1500 psig
<b>Ambient Temperature</b> (A case extension is used for extreme temperatures or when body insulation is used.)	-40° to 160°F (-40° to 71°C)

\*Gauges are standard 0-60 psi. Higher pressure gauges are available for an additional fee.

ELECTRIC ON/OFF SWITCH	
<b>Output</b>	
Electric - Micro Switch Type	Proportional band adjustment
SPDT	7–55%
DPDT	20–150%
<b>Switch Ratings</b>	
SPDT	15 amps at 125, 250, or 480 V.A.C.
DPDT	10 amps at 125 V.A.C.
<b>Certifications - Hazardous Locations</b>	
SPDT	NEMA 1,7 & 9 UL and CSA certified: Class I, Groups C&D; Class II, Groups E,F,&G
DPDT	NEMA 1,7 & 9 UL and CSA certified: Class I, Groups B,C,&D; Class II, Groups E,F,&G

# Materials

PNEUMATIC PILOTS	
Body	
Throttle	Aluminum w/Aluminum Seat
Snap	Aluminum w/Aluminum Seat
Envirosave™	Aluminum w/Aluminum Seat
Gasket/diaphragm	Nitrile
Internal Valving	302 SST
Filter Element	40 Micron SST
Screws & Nuts	SST

ELECTRIC ON/OFF SWITCH	
Micro-Switch Enclosure	Cast aluminum
Junction Box	Cast aluminum

GENERAL	
Body - LLC	
1001/1001A	ASTM A696/A105 (std) -20 to +600°F (-29 to +316°C) ASTM A351 CF8M/A182 -70 to +600°F (-57 to +316°C)
1001XL	ASTM A216 WCC/A105 (std) -20 to +600°F (-29 to +316°C) ASTM A351 CF8M/A182 -70 to +600°F (-57 to +316°C)
Hammer Nut (where applicable)	ASTM A105
Sight Glass (For special DU/AU union body)	Acrylic -20 to +200°F (-29 to +93°C) Pyrex -20 to +400°F (-29 to +204°C)
Displacers	PVC -20 to +140°F (-29 to +60°C) Acrylic -20 to +200°F (-29 to +93°C) 316 SST -70 to +600°F (-57 to +316°C)
Displacer Arm	316 SST
Vertical Hanger (swivel for vertical displacer position)	316 SST
Chain	304 SST (for vertical extension and/or split displacer)
Shaft	316 SST -70 to +600°F (-57 to +316°C)
Bearing Blocks	316 SST -70 to +600°F (-57 to +316°C)
Bearings	440 SST -70 to +600°F (-57 to +316°C)
Shaft Seals	Nitrile -20 to +180°F (-29 to +82°C) Nitrile lo-temp -50 to +180°F (-46 to +82°C) Fluorocarbon -20 to +400°F (-29 to +204°C) Aflas -20 to +600°F (-29 to +316°C) EPR -50 to +250°F (-46 to +121°C)
Case & Cover	Die cast chromated aluminum with powder coat
Supply and Output Gauges	Brass (standard) 0-60 psig 316 SST 0-60 psig Brass liquid fill 0-60 psig 316 SST liquid fill 0-60 psig
Torque Bar	Aluminum (standard) 303 SST
Flapper Bar	303 SST
Spring Adjusting Knob	Aluminum (standard) 303 SST
Fulcrum	Nylon w/SST screw
Balancing Spring	Light -SST w/green marking Medium-SST w/ho marking Heavy-SST w/yellow marking Extra Heavy-SST w/red marking

Note:  
Materials that are certified compatible for NACE service are available upon request.

## How to order

**Determine the model number.** This specifies series and connection size; pilot type; left, right or back mount; pilot action; seals; and service condition.

**Required application information:**

- A. Fluid media
- B. Process temperature (maximum and minimum)
- C. Process pressure
- D. Vessel size and diameter (distance of connection from bottom of vessel, any obstructions that may hinder performance)
- E. Body connection type, size, and rating
- F. Displacer position (vertical or horizontal)
- G. Controller mount (right or left) if applicable
- H. Pilot action
- I. Area electrical classification if applicable
- J. Top level or interface

**Right-hand mount vs. Left-hand mount**

The Series 1001 and Series 1001A can be configured as right-hand mount or left-hand mount. The orientation of the displacer to the controller (while facing the front side of the controller) designates the mounting style. The mounting can be adjusted in the field. The Series 1001XL back-mount controller is utilized when neither right-hand or left-hand mounts are practical.

**Electric level switch**

The electric level switch uses the force balance principle to apply force to a standard Micro-switch.

Two standard switches are available, both with explosion-proof enclosures: single pole double throw (SPDT) or double pole double throw (DPDT). Rating for SPDT switch is 15 amps at 125, 250, or 480 volts A.C. The DPDT switch rating is 10 amps at 125 or 250 volts A.C.

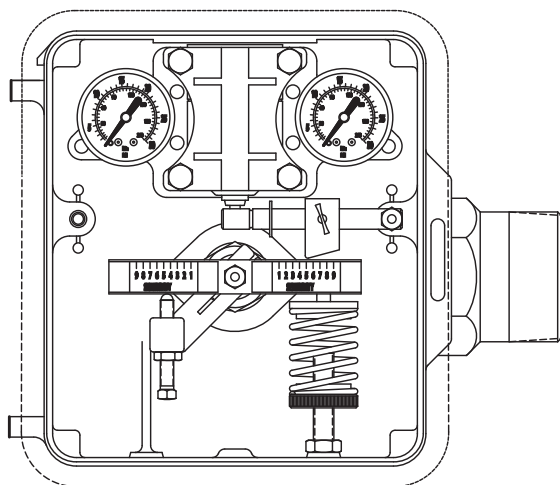

**Right-hand mount**

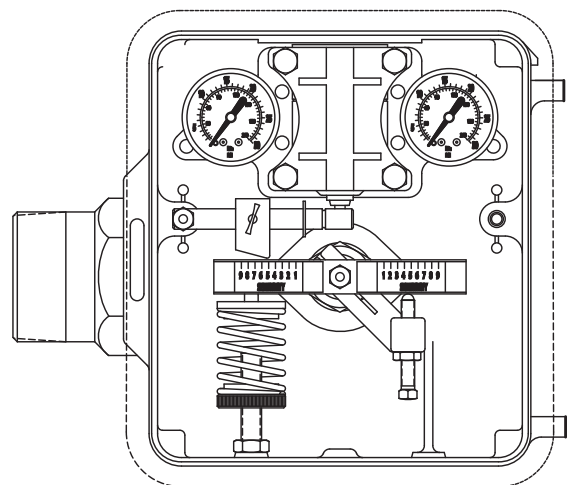

**Left-hand mount**

# Model code: Level Controllers



**A**

SERIES MODEL	
Code	Series
1001	1001 Model
1001A	1001A Model
1001XL	1001XL Model

**B**

END CONNECTION SIZE	
Code	Size
2	2"
3	3"
4	4"

**C**

END CONNECTION TYPE	
Code	Type
RF	Flanged Raised Face
RJ	Flange Ring Type Joint
SM	Screwed Male NPT
AU	Hammer Union ACME Thread
DU	Hammer Union Dover/STD Thread

**D**

PRESSURE RATING			
Code	ANSI	MWP @100°F	Connection Type
02	150#	285PSI	Flanged only
07	300#	740PSI	Flanged only
14	600#	1440PSI	Flanged only
15		1500PSI	Hammer Union
21	900#	2220PSI	Flanged only
36	1500#	3750PSI	Flanged only
60	2500#	6170 PSI	NPT or Flanged

**E**

MATERIAL: BODY/SHAFT/BLOCK		
Code	Body	Shaft/Bearing Block
-	WCC CS (A696)	316SS
N	WCC CS (A696) NACE	316SS
R	316SS NACE	316SS
S	316SS	316SS

**F**

PILOT MODE		
Code	Type	Signal
D	DPDT	Electric (On/Off)
E	SPDT	Electric (On/Off)
B	Envirosave	Pneumatic (On/Off)
S	Snap	Pneumatic (On/Off)
T	Throttle	Pneumatic (Modulating)

**G**

MOUNTING CASE	
Code	Type
B	Back Mount (XL Models Only)
L	Left Hand Mount
R	Right Hand Mount

**H**

PILOT ACTION		
Code	Action	Behavior
D	Direct	Level rises, output signal increases
R	Reverse	Level rises, output signal decreases

**I**

SEAL MATERIAL			
Code	O-Ring Material	Temp. Range*	Service
A	Buna-N	-20 to 180°F	STD Only
E	EPR	-20 to 250°F	NACE or STD
F	Viton	-20 to 400°F	NACE or STD
S	Aflas	-20 to 400°F	NACE or STD
L	Low Temp Buna	-50 to 180°F	STD Only

\*Unit temperature rating subject to selection of displacer. See displacer chart.

**J**

PRESSURE GAUGES			
Code	Material	Range	Used on
-	Bronze (Dry)	0-60PSI	1001/1001A/1001XL
K	316SS (Dry)	0-60PSI	1001/1001A/1001XL
M	Bronze (Liquid Filled)	0-60PSI	1001A/1001XL
Q	316SS (Liquid Filled)	0-60PSI	1001A/1001XL
R	No Gauges (Electric Models)		1001/1001A/1001XL

**K**

SERVICE CONDITION		
Code	Type	Used on
B	Standard	1001/1001A/1001XL
C	Vibration*	1001A/1001XL

\*Must use Liquid Filled Gauges

**L**

CASE ENCLOSURE TYPE	
Code	Type
A	Standard Case (1001 Only)
G	Weather-resistant Case Only
H	Weather-resistant Case and Piped Exhaust
	Weather-resistant Case, Piped Exhaust and Special Marine Internals
K	Weather-resistant Case and Special Marine Internals

**M**

SPECIAL OPTIONS	
Code	Type
-	Standard
A	High Temp (Max 600F) or Low Temp Service (Low -50F)

DISPLACER CHART		
Material	Temp Range	Max Pressure
PVC	-20 to 140°F	6170 PSIG
Acrylic	-20 to 200°F	6170 PSIG
SST-2	-70 to 600°F	2000 PSIG*

\*3000PSIG Option available. Consult Factory

NOTE: Additional materials (not shown above) are available for extreme service conditions.

# Dimensions

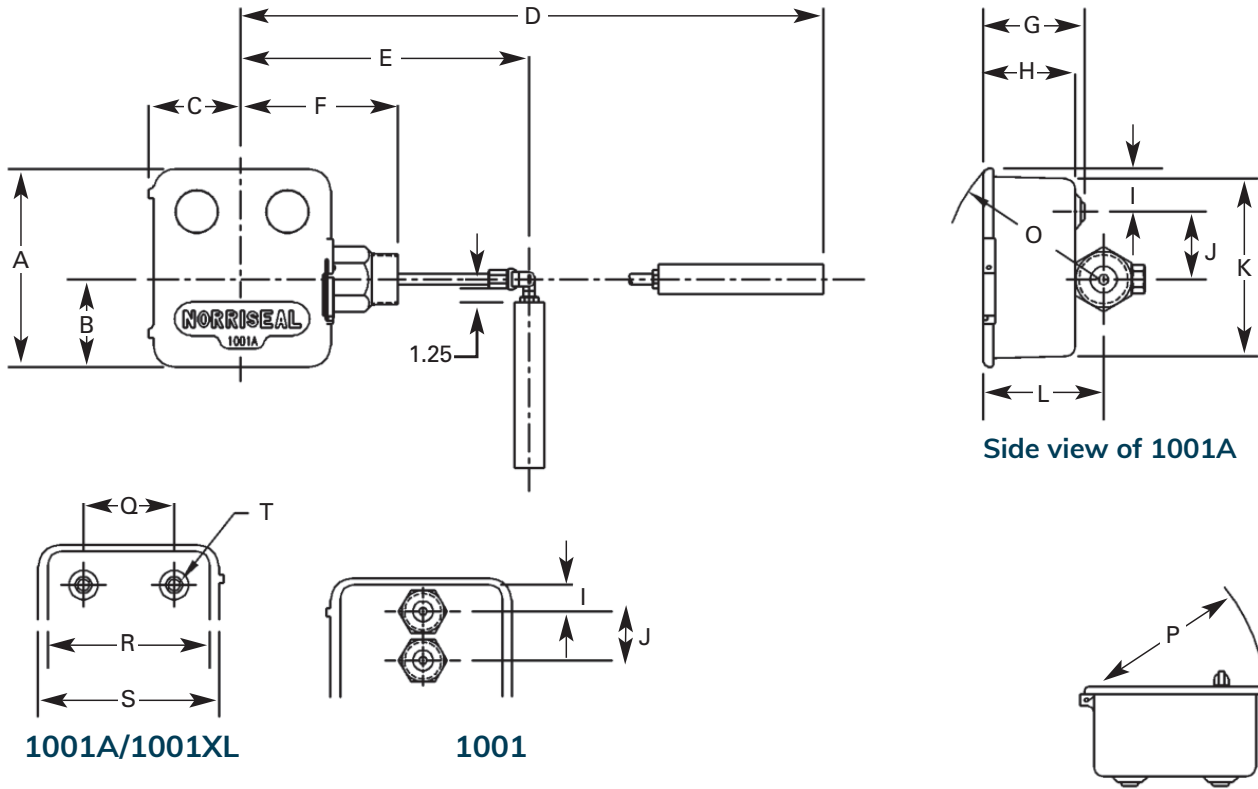

MODEL			
	1001	1001A	1001XL
A	7.68	8.74	8.74
B	3.00	3.85	3.00
C	4.09	4.13	4.13
D	24.43*	24.43*	24.44*
E	13.67*	13.67*	13.67*
F	*	*	*
G	3.12	4.36	4.36
H	2.75	3.95	3.95
I	0.90	1.90	1.90
J	1.00	2.98	2.98
K	7.68	7.98	7.98
L	4.00	5.19	-
O	6.00	7.13	-
P	7.75	7.85	7.85
Q	-	4.00	4.00
R	-	7.06	7.06
S	-	8.01	8.01
T	¼NPT	¼NPT	¼NPT
U	4.75	4.87	5.16

\* See page 9 for "F" dimension for different type of connections.

\* Using standard 1.88 dia. X 12 inch displacer and 12.5 inch displacer arm.  
 Length is dependent upon displacer arm and displacer.  
 Swivel length = 1.17"  
 12.5" arm + 1.17 Swivel = 13.67" Total

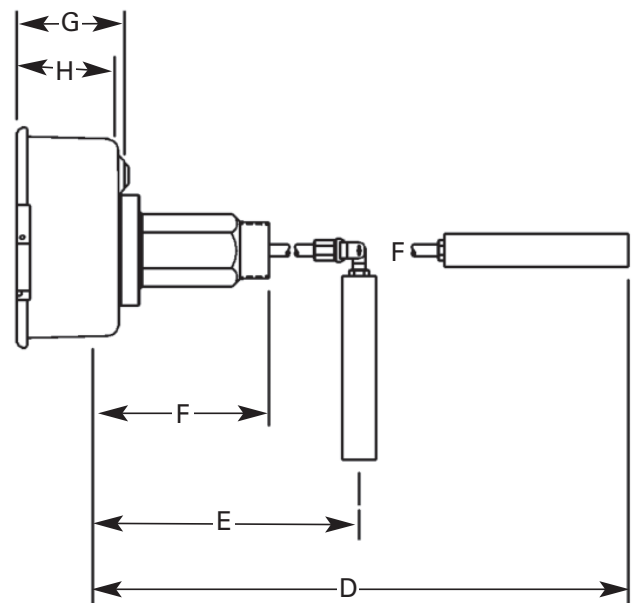

Side view of 1001XL

# Dimensions

DIMENSIONS "F"			
Body Styles X	Body Size		
	2.00	3.00	4.00
Flanged	6.88	-	-
-150 RF	6.50	6.56	6.56
-300 RF	6.81	6.75	6.88
-300 RTJ	7.06	7.00	7.25
-600 RF	7.19	7.13	7.50
-600 RTJ	7.25	7.31	7.56
-900 RF	8.00	9.63	10.13
-900 RTJ	8.06	9.69	10.19
-1500 RF	8.00	10.25	10.63
-1500 RTJ	8.06	10.31	10.69
-2500 RF	9.13	11.00	11.75
-2500 RTJ	9.19	11.13	11.94

WEIGHTS			
Body Styles X	Body Size		
	2.00	3.00	4.00
Screwed Male NPT	18	NA	NA
Flanged	26	NA	NA
-150 RF	25	30	34
-300 RF	27	35	45
-300 RTJ	27	35	45
-600 RF	29	37	55
-600 RTJ	29	37	55
-900 RF	40	51	75
-900 RTJ	40	51	75
-1500 RF	45	72	95
-1500 RTJ	45	72	95
-2500 RF	61	110	150
-2500 RTJ	61	110	150

Weights are for 1001. For 1001A add 1 lb. and for 1001XL add 2 lb.

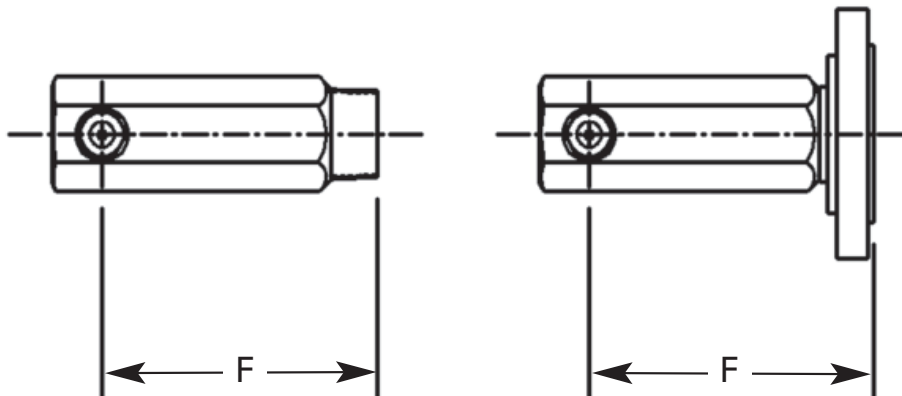

Series 1001 and 1001A

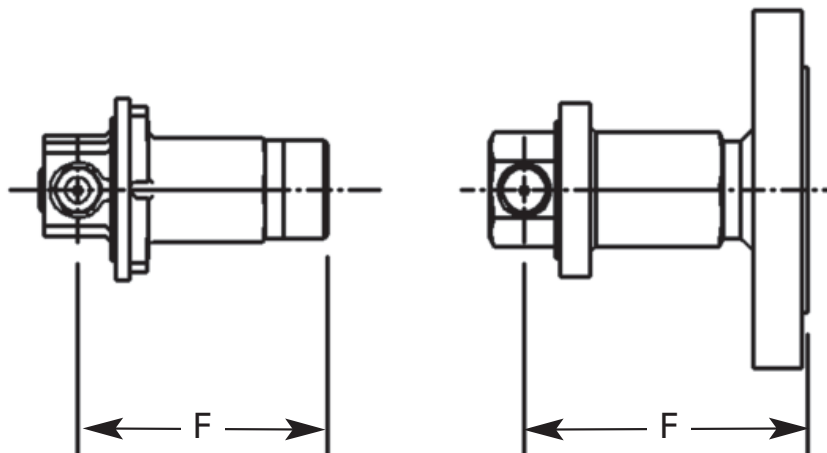

Series 1001XL

# Series 1006 Vertical Chambers

The Series 1001 and Series 1001A can be externally mounted using our Series 1006 vertical or horizontal external chambers. These external chambers provide more stable operation for vessels with internal obstruction or considerable internal turbulence.

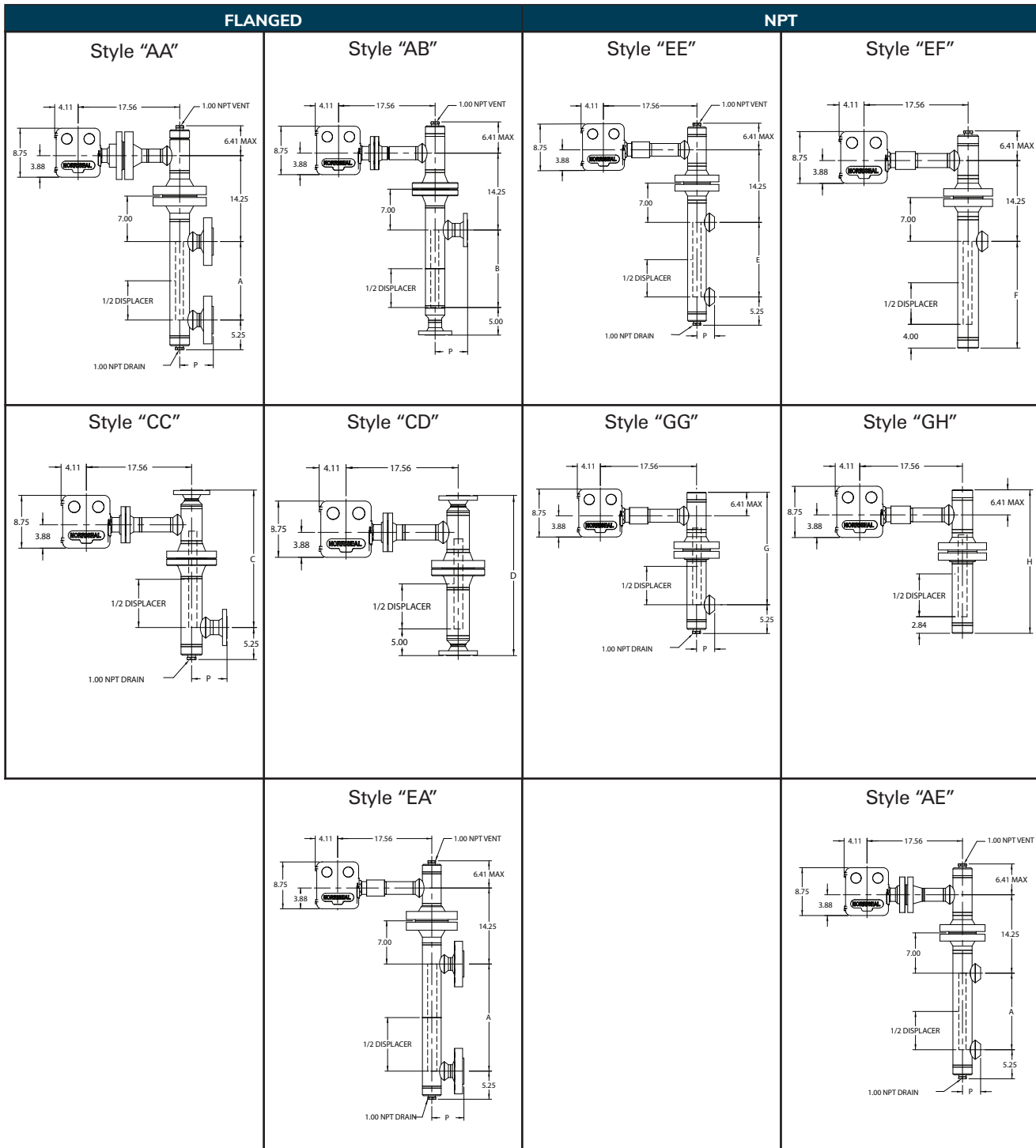

Other process connections available.

# Series 1006 Vertical Chambers

PROCESS CONNECTIONS DIMENSIONS (INCHES)				
Type	Style	Displacer	Dim**	Dim
Flanged	AA	14	A	14
		32		32
	AB	14	B	14
		32		37
	AE	14	E	14
		32		32
	CC	14	C	21
		32		39
	CD	14	D	26
		32		44
NPT	EA	14	A	14
		32		32
	EE	14	E	14
		32		32
	EF	14	F	18
		32		36
	GG	14	G	19
		32		37
	GH	14	H	23
		32		41

PROCESS CONNECTIONS (INCHES)					
ANSI Class		DIM	150	300	600
3.00 x 1.50 flg	RF	P	5.62	5.88	6.19
	RTJ	P	5.88	5.62	6.19
3.00 x 2.0 flg	RF	P	5.88	6.12	6.50
	RTJ	P	6.12	6.44	6.56
4.00 x 1.50 flg	RF	P	6.12	6.38	6.69
	RTJ	P	6.38	6.62	6.69
4.00 x 2.0 flg	RF	P	6.38	6.62	7.00
	RTJ	P	6.62	6.94	7.06

NPT Size	DIM	1.0 in	1.5 in	2.0 in
3.00 x NPT	P	3.12	3.19	3.31
4.00 x NPT	P	3.62	3.69	3.81

\*\*Other displacer lengths available on request.  
 \*\*Charted dimensions are for process connecting piping.  
 All other dimensions may vary with respect to flange size and ANSI class.

## Position of process connections

The following diagram illustrates the location of the process connections and level controller relative to Position 1 (P1) which is zero. Refer to Model Code, Position Process Connection on page 13.

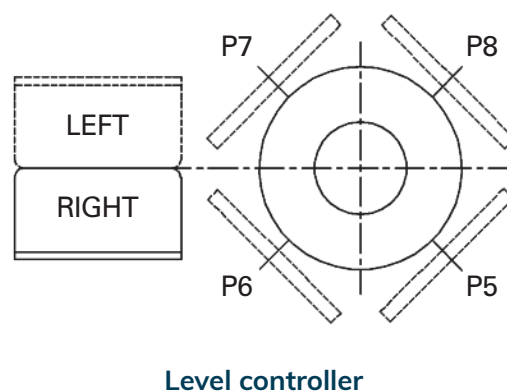
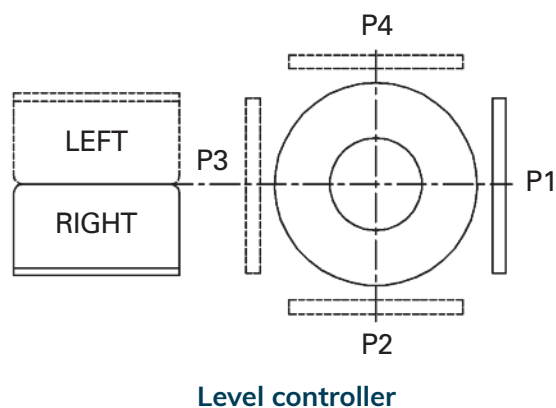

# Domes and horizontal chambers

## Series 1006D Dome

To specify a dome only (this is the top of the vertical chamber), add a suffix letter 'D' to the end of the Series Number. Refer to the Model Code, Vertical Dome Style on page 13.

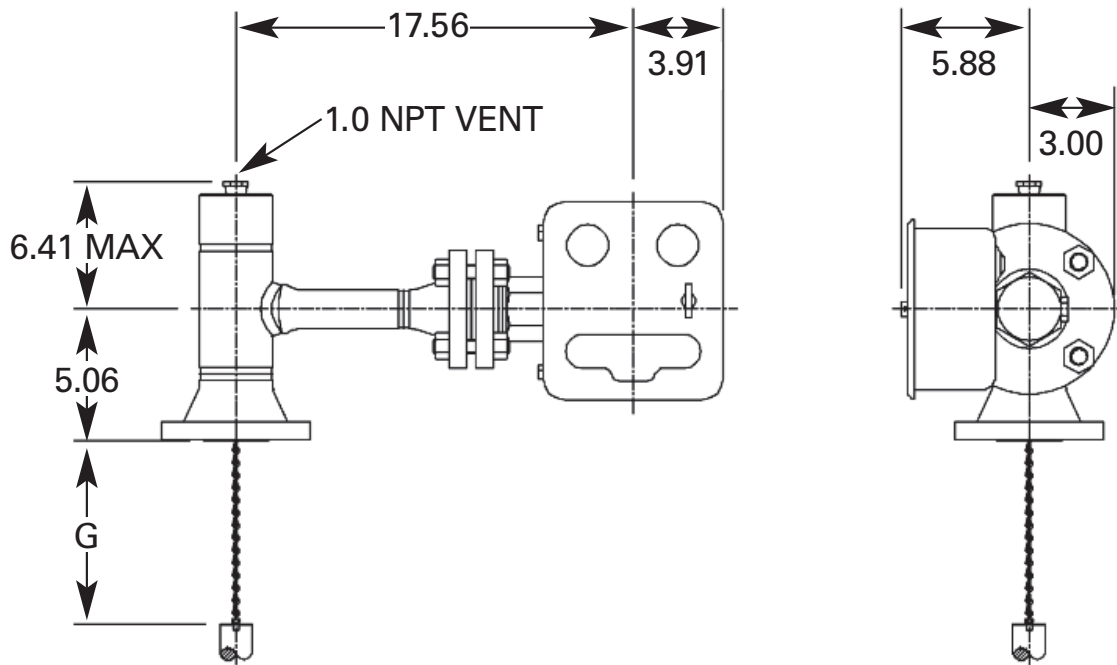

Note: Standard chain extension is 12". Longer chains available on request.

## Series 1006 Horizontal Chamber

(For Model Code, refer to page 14)

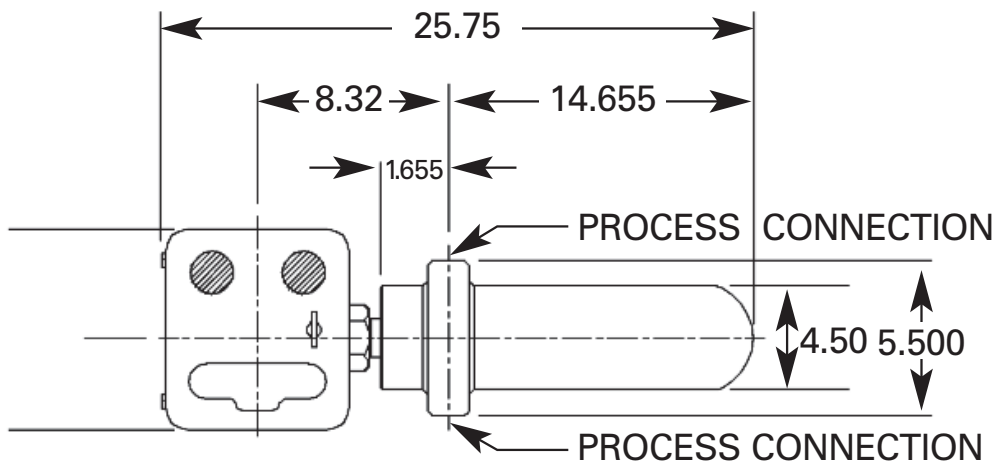

Typical NPT level controller & chamber  
(flanged configuration available)

# Model code: Vertical chambers and domes

3
A
A
14
-
20
RF
14
-
P1

A
B
C
D
E
F
G
H
I
J

**A**

CHAMBER/DOME PIPE SIZE	
Code	Description
3	3.00" (Std.)
4	4.00"

**B**

VERTICAL DOME STYLE	
Code	Description
A	Flanged LLC w/NPT Vent
C	Flanged LLC w/top Flanged Process Conn
E	Screwed LLC w/NPT Vent
G	Screwed LLC w/Top NPT Process Conn

**C**

VERTICAL CHAMBER STYLE			
Code	Type Process Connection	Type Level Control Connection	Process Connection Mounting Style
A	Flanged	See Dome	Side Top-Side Btm
B	Flanged	See Dome	Side Top-Btm
C	Flanged	See Dome	None-Side Btm
D	Flanged	See Dome	None-Btm
E	Screwed	See Dome	Side Top-Side Btm
F	Screwed	See Dome	Side Top-Btm
G	Screwed	See Dome	None-Side Btm
H	Screwed	See Dome	None-Btm
O	1006 Dome Only		

**D**

CENTER-TO-CENTER LENGTH	
Code	Description
14	14.00 Inch
32	32.00 Inch
48	48.00 Inch
0	Dome Only

Note: For other lengths, please consult factory. Max Length is 60".

**E**

DOME/CHAMBER MATERIAL	
Code	Description
-	Carbon Steel A105
N	Carbon Steel - NACE, A105/A106
R	316L Stainless Steel - NACE
S	316 Stainless Steel

**F**

PROCESS CONNECTION	
Code	Description
10	1.00 Inch
15	1.50 Inch
20	2.00 Inch

- NOTES:
- Controller-to-chamber connection is always 2 in.
  - Standard vent and drain connections are 1 in. NPT.
  - Additional materials (not shown above) are available for extreme service conditions.

**G**

TYPE PROCESS CONNECTION	
Code	Description
RF	Flanged - RF (Raised Face)
RJ	Flanged - RJ (Ring Type Joint)
SC	Screwed Female

NOTE:  
Specify when gauge glass connections are required.  
Give size, position, and center-to-center dimensions.

**H**

RATING PROCESS CONNECTION		
Code	Description	
02	Flanged (ANSI)	150
07		300
14		600
21		900
36		1500
14	NPT (WP)	1480

- NOTE:
1. Flanged-LLC & dome/chamber connection rated same as process connection (except ANSI 150 Class). Dome/chamber connection is ANSI 300.
  2. Threaded-dome/chamber connection is ANSI 600 class; higher pressure classes available.

**I**

STUD & GASKET MATERIAL			
Code	Stud/Nut	Gasket	
		RF or FF	RJ
-	ASTM A193-B7/ ASTM A194-2H	316L/GRF CSTL GR	CSTL Solid
A	ASTM A193-B8M/ ASTM A194-8M	316L/GRF CSTL GR	316 SS Solid
C <sup>1</sup>	ASTM A193-B7/ ASTM A194-2H	INC/GRF CSTL GR	-
L <sup>1</sup>	ASTM A193-B7M/ ASTM A194-2HM	INC/GRF 316SS GR	316 SS Solid

NOTE:  
<sup>1</sup> For NACE service.

**J**

POSITION PROCESS CONNECTION	
Code	Description
P1	0 Degrees w/LLC at 180 Degrees
P2	90 Degrees w/LLC at 180 Degrees
P3	180 Degrees w/LLC at 180 Degrees
P4	270 Degrees w/LLC at 180 Degrees
P5	45 Degrees w/LLC at 180 Degrees
P6	135 Degrees w/LLC at 180 Degrees
P7	225 Degrees w/LLC at 180 Degrees
P8	315 Degrees w/LLC at 180 Degrees

## Model code: Horizontal chambers

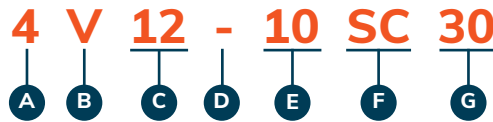

**A**

CHAMBER PIPE SIZE	
Code	Description
4.0	4.00

**B**

HORIZONTAL CHAMBER STYLE			
Code	Type Process Connection	Type Level Control Connection	Process Connection mounting Style
L	Screwed	Flanged	Top-Bottom
V	Screwed	Screwed	Top-Bottom

Please note: not all available options are shown.  
Consult factory for additional configurations.

**C**

DISPLACER LENGTH	
Code*	Description
12	12.00 Inch

**D**

CHAMBER MATERIAL	
Code	Description
-	Carbon Steel A105/A106
N	Carbon Steel - NACE, A105/A106
S	316 Stainless Steel
W	316 L Stainless Steel - NACE

NOTES:

- Controller-to-chamber connection is always 2 in.
- Additional materials (not shown above) are available for extreme service conditions.

**E**

PROCESS CONNECTION	
Code	Description
10	1.00 Inch

**F**

TYPE PROCESS CONNECTION	
Code	Description
SC	Screwed Female

**G**

RATING PROCESS CONNECTION		
Code	Description	
30	*NPT (WP)	3000

\*Standard. Higher pressures available on application

# Applications

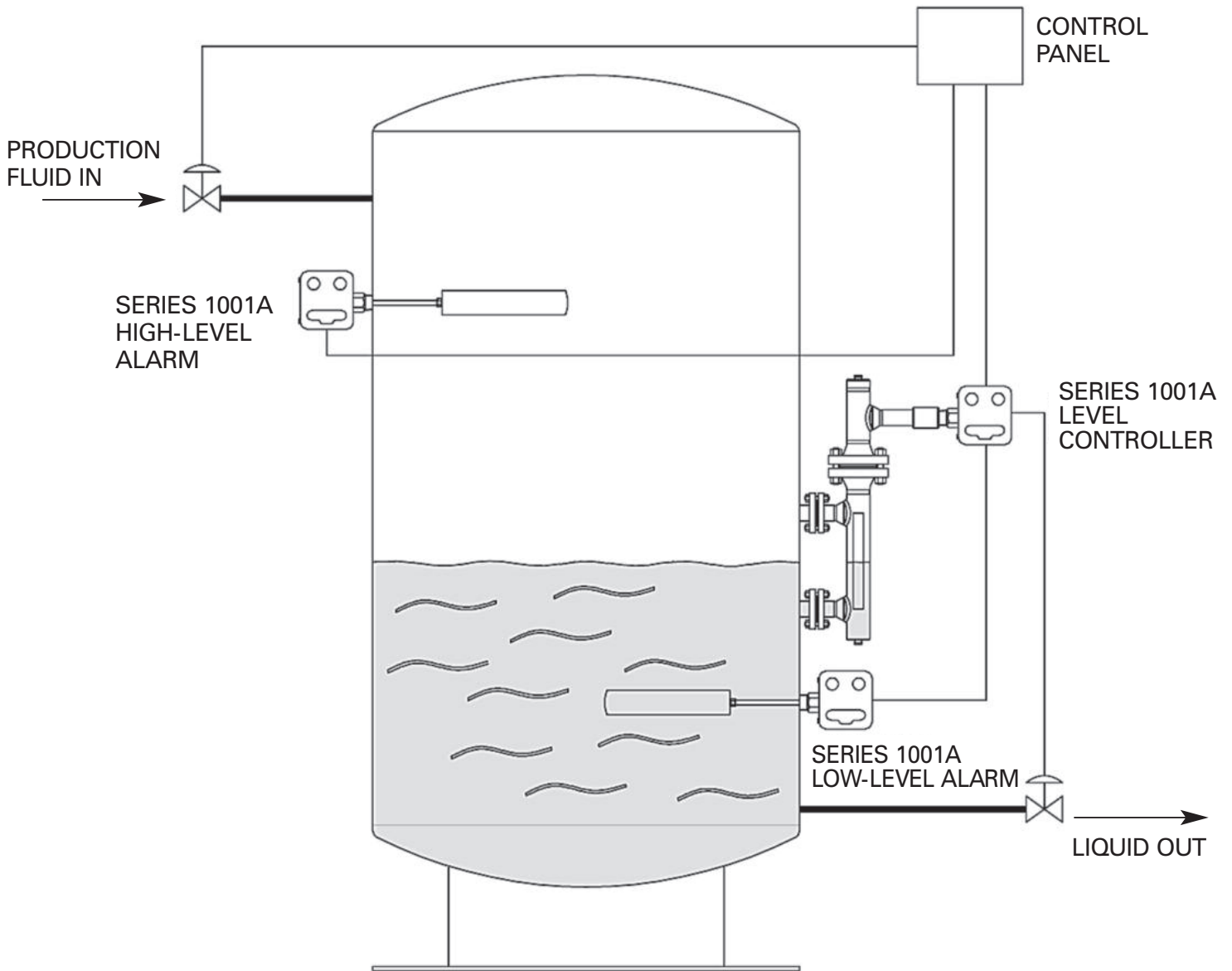

## Common applications

1. Custody Transfer Measurement Systems
2. Separators
3. Dehydrators
4. Heater Treaters
5. Well Test Systems
6. Interface Detection
7. Compressor Scrubbers
8. Offshore Production Facilities

# Why you can depend on genuine Norriseal-Wellmark products

- In-house engineering and technical support
- In-depth applications experience
- Award-winning innovation and ongoing product development
- ISO 9001 certified manufacturing
- Over five decades of industry service
- Compliance with all industry standards and specifications
- Responsive service and prompt delivery
- Field support available worldwide

Contact Norriseal-Wellmark for more information about our products and services.

### Texas

Houston . . . . . 713-466-3552

### Oklahoma

Oklahoma City . . . . . 405-672-6660

### Louisiana

Broussard . . . . . 337-837-3223



Follow us on LinkedIn.

### Request for Quote

NRS\_RFQ@championx.com



NorrisealWellmark.com

Norriseal-Wellmark | 11122 W Little York Rd | Houston, TX 77041

This document is provided on an "as is" basis without warranties of any kind. Norriseal-Wellmark DISCLAIMS ALL WARRANTIES, EXPRESS OR IMPLIED, INCLUDING, BUT NOT LIMITED TO, IMPLIED WARRANTIES OF MERCHANTABILITY, FITNESS FOR A PARTICULAR PURPOSE OR SUITABILITY FOR ANY PURPOSE, TITLE, AND NON-INFRINGEMENT. While reasonable care has been taken in the preparation of this document, Norriseal-Wellmark does not represent or warrant that the contents of this document are accurate, complete, reliable, current or error-free.